

- Direct connection to tank boss allows housing to be self-supportive
- Easy assembly and maintenance
- STANDARD product
 - Standard surface finish & tri-clamp connection
- PLUS product
 - Available as STANDARD or for Atex applications
 - Standard, sanitary and sanitary electropolished surface finishes available
 - Connection choices

(Also see HSVLP (L-Port) Datasheet)



Specification

STANDARD Range

Materials of Construction

- Housing: 316L Stainless Steel
- Seals: Silicone FDA
- Clamps: 304 Stainless Steel

Surface Finish

- Internal: As welded
- External: Polished 0.8 μm (32 $\mu\text{In Ra}$)

All finishes pickled & passivated.

PLUS Range

Materials of Construction

- Housing: 316L Stainless Steel
- Seals: EPDM FDA
PTFE FDA
Silicone FDA
Viton FDA
- Clamps: 304 Stainless Steel

Note: Seal used only to position bowl clamp arrangement.

Surface Finish

- Standard Finish
 - Internal: As Welded
Pickled & Passivated
 - External: Polished 0.8 $\mu\text{m Ra}$ (32 $\mu\text{In Ra}$)
- Sanitary Finish
 - Internal: Polished 0.4 $\mu\text{m Ra}$ (16 $\mu\text{In Ra}$)
 - External: Polished 0.25 $\mu\text{m Ra}$ (10 $\mu\text{In Ra}$)
- Sanitary Electropolished Finish
 - Internal: Polished 0.4 $\mu\text{m Ra}$ (16 $\mu\text{In Ra}$) and Electropolished
 - External: Polished 0.25 $\mu\text{m Ra}$ (10 $\mu\text{In Ra}$)

Welding

All assembly welds are full penetration. All welds are crevice and undercut free. *Weld finish & detail drawings available upon request.*

Certification

Supplied as standard with vessel inspection certificate.

Material Test Certification

EN10204 3.1 supplied upon request.

Recommended Operation Guidelines Sizing

Sizing vent vessels particularly for vacuum sensitive tanks can require specialist advice. It is important that VENT housings are sized on maximum gas flow capacity under actual operation conditions.

Vacuum Protection

Where a tank is vacuum sensitive, there is a risk of tank collapse. In such cases the fitting of an appropriately rated bursting disc (or similar) and, if necessary a pressure relief valve, is highly recommended.

Physical Characteristics

Bowl Height	Dimensions (mm)			Typical Weight
	'A'	'B'	'C'	
A Size 125 mm [5"]	75 mm [2.9"]	195 mm [7.7"]	130 mm [5.1"]	1.0 Kg [2.2lbs]
B Size 65 mm [2 1/2"]	75 mm [2.9"]	140 mm [5.5"]	70 mm [2.8"]	0.9 Kg [1.9lbs]
125 mm [5"]	132 mm [5.2"]	242 mm [9.5"]	194 mm [7.6"]	2.2 Kg [4.8 lbs]
250 mm [10"]	132 mm [5.2"]	392 mm [15.4"]	313 mm [12.3"]	2.8 Kg [6.1 lbs]
500 mm [20"]	132 mm [5.2"]	642 mm [25.3"]	561 mm [22.1"]	3.8 Kg [8.3 lbs]
750 mm [30"]	132 mm [5.2"]	890 mm [35.0"]	809 mm [31.8"]	4.8 Kg [10.6 lbs]
1000 mm [40"]	132 mm [5.2"]	1138 mm [44.8"]	1057 mm [41.6"]	5.8 Kg [12.8 lbs]

Dimensions shown are based on the STANDARD range. For accurate dimensions, please contact Parker domnick hunter.

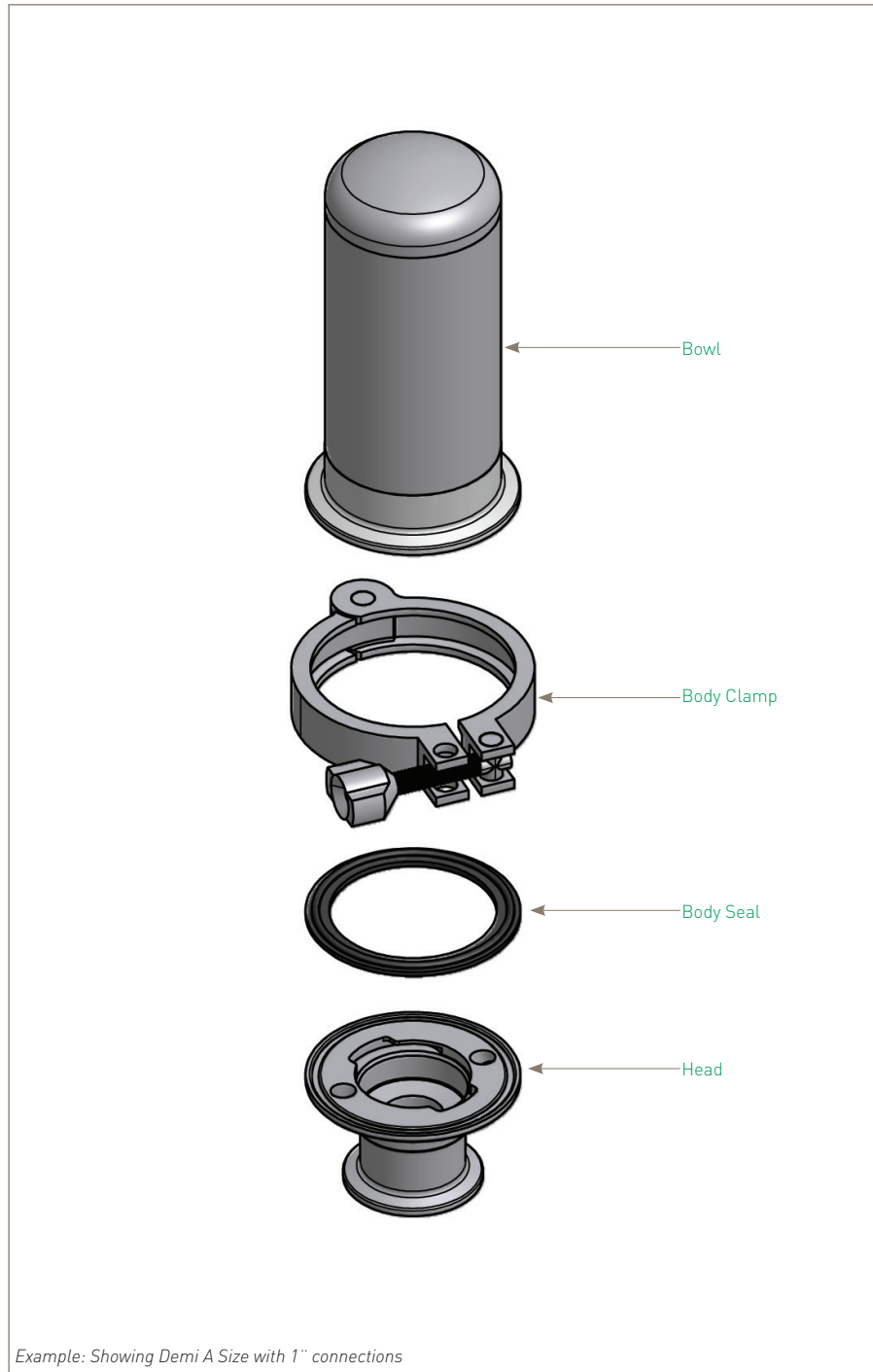
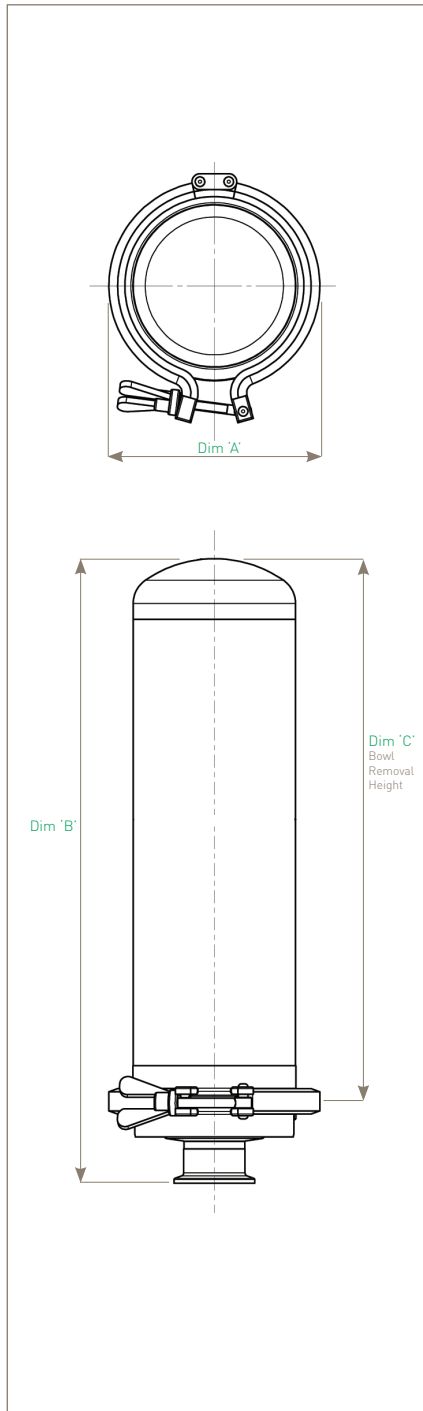

Example: Showing Demi A Size with 1" connections

The PLUS product range is available with many options of connections, vents, drains, surface finish, seals classification, etc. Please see product coding.

Note: All housings are fully vacuum rated.

STANDARD Range - K to 20"

HSV 01 - -

Code Vessel Class	Code Length (Nominal)	Code Connection Size	Code Standard	Code Cartridge	Code Seal
DH Vent Housing	K 5" (125 mm) 1 10" (250 mm) 2 20" (500 mm)	Y 1 1/2" (38.1 mm)	T Tri-Clamp	C 226	S Silicone

STANDARD Range - Demi A & B

HSV 01 - -

Code Vessel Class	Code Length (Nominal)	Code Connection Size	Code Standard	Code Cartridge	Code Seal
DH Vent Housing	A 5" (125 mm) B 2 1/2" (65 mm)	B 1" (25.4 mm)	T Tri-Clamp	T 126	S Silicone

PLUS Range - K to 40"

HSV 01 - -

Code Vessel Class	Code Length (Nominal)	Code Connection Size	Code Standard	Code Cartridge	Code Seal	Code Surface Finish	Internal	External	Code Tagged
DH Standard AT ATEX	K 5" (125 mm) 1 10" (250 mm) 2 20" (500 mm) 3 30" (750 mm) 4 40" (1000 mm)	C 2" (50.8 mm) Y 1 1/2" (38.1 mm)	B BSPP (F) D DIN11851(M) F ANSI RF150 L BS4504 DIN2633 N NPT (F) T Tri-Clamp W BS / ISO Pipe	C 226	E EPDM P PTFE S Silicone V Viton	B Sanitary I Standard P Sanitary Electropolished	0.4 µm As Welded	0.25 µm 0.8 µm 0.25 µm EP	T Yes X No

For Tagged Options customer identification numbers required at time of ordering

PLUS Range - Demi A & B

HSV 01 - -

Code Vessel Class	Code Length (Nominal)	Code Connection Size	Code Standard	Code Cartridge	Code Seal	Code Surface Finish	Internal	External	Code Tagged
DH Standard AT ATEX	A 5" (125 mm) B 2 1/2" (65 mm)	B 1" (25.4 mm)	B BSPP (F) D DIN11851 F ANSI RF150 L BS4504 DIN2633 N NPT (F) T Tri-Clamp	T 126	E EPDM P PTFE S Silicone V Viton	B Sanitary I Standard P Sanitary Electropolished	0.4 µm As Welded	0.25 µm 0.8 µm 0.25 µm EP	T Yes X No

For Tagged Options customer identification numbers required at time of ordering