



Hydraulic Rotary Actuators

Catalog 1800/USA



Overview

Wherever in the world machinery is designed, manufactured, or used, Parker is there to meet your automation application requirements—with hydraulic and pneumatic component selection, worldwide availability, and technical assistance.

This catalog contains the information you need to order hydraulic automation components. Arranged by product group, it contains complete specifications, dimensions, and ordering information on Parker

hydraulic automation components, including technical data and reference material for designers, builders, and users of motion control machinery. No more shuffling through dozens of separate catalogs from dozens of separate suppliers.

And when you're ready to order, call your local Parker distributor for fast delivery and service. Or call your Parker Automation Sales Office.

Contents

Page No./Section

General Information	II
Applications	III
Selection Guide	IV - V
Product Highlights	VI
Contents	VII
LTR Series 1000 PSI Rotary Actuators	Section A
HTR Series 3000 PSI Rotary Actuators	Section B
M Series Heavy Duty Mill Actuators	Section C
Rotary Actuator Engineering Guidelines	Section D

 **WARNING**

FAILURE OR IMPROPER SELECTION OR IMPROPER USE OF THE PRODUCTS AND/OR SYSTEMS DESCRIBED HEREIN OR RELATED ITEMS CAN CAUSE DEATH, PERSONAL INJURY AND PROPERTY DAMAGE.

This document and other information from Parker Hannifin Corporation, its subsidiaries and authorized distributors provide product and/or system options for further investigation by users having technical expertise. It is important that you analyze all aspects of your application and review the information concerning the product or system in the current product catalog. Due to the variety of operating conditions and applications for these products or systems, the user, through its own analysis and testing, is solely responsible for making the final selection of the products and systems and assuring that all performance, safety and warning requirements of the application are met.

The products described herein, including without limitation, product features, specifications, designs, availability and pricing, are subject to change by Parker Hannifin Corporation and its subsidiaries at any time without notice.

Offer of Sale

The items described in this document are hereby offered for sale by Parker Hannifin Corporation, its subsidiaries or its authorized distributors. This offer and its acceptance are governed by the provisions stated in the "Offer of Sale".

**Parker . . .
Leading the Industry**

Parker leads the industry in development of new and innovative features to make rack and pinion rotary actuators more reliable, efficient and safe. With a firm commitment to product quality and design research, Parker rotary actuators are continually being improved so that you can enjoy benefits such as long service life and increased productivity.

What Is a Rack & Pinion Rotary Actuator?

Parker rotary actuators convert fluid power into rotary motion for a wide variety of industrial applications. Pressurized fluid is applied to a circular piston inside a cylinder which pushes a rack across the pinion gear. This action turns the shaft, generating rotary motion. This motion is transferred through the shaft to the machinery for applications such as upending, turning, roll-over, tilting, indexing, transferring, mixing, valve operating, tensioning and clamping.

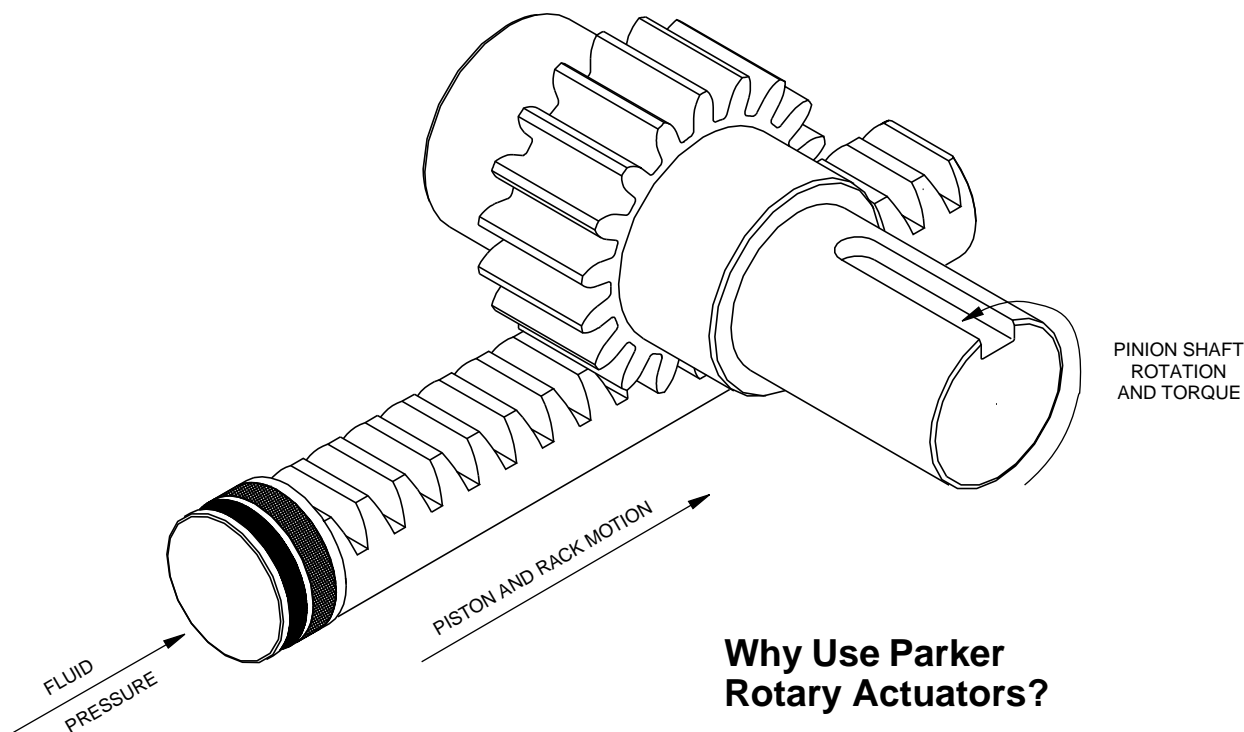

Where Can Parker Rack & Pinion Actuators Be Used?

- Material Handling
- Machine Tool
- Primary Metals
- Rubber and Plastics Machinery
- Mobile Equipment
- Robotics
- Packaging
- Valve Actuation
- Multi-Process Industry
- Cranes and Hoists
- Mining and Oil Field Equipment
- Military
- Commercial Marine

Why Use Parker Rotary Actuators?

- Provides uniform torque in both directions.
- Simple design.
- Wide range of sizes.
- High torque output in a small package size.
- More efficient operation and longer time between servicing.
- Performs under the most adverse ambient conditions.
- No external linkage needed for rotary motion.
- Good load holding capability with no drift.
- Optional cushions can stop inertial loads*.
- Rotation can be specified to fit exact application needs.
- Will support radial and thrust loads.

* Within actuator limits.

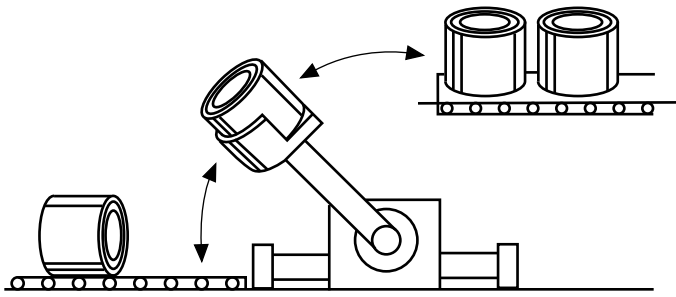

**TRANSFER
(UPENDING/DOWNENDING)**

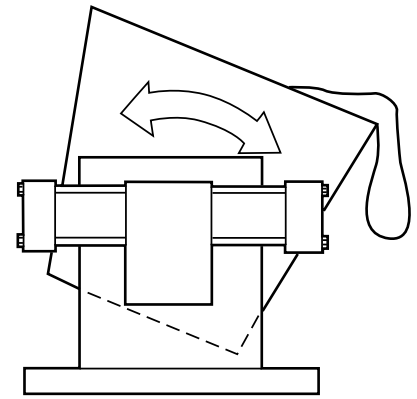

UNLOADING/DUMPING

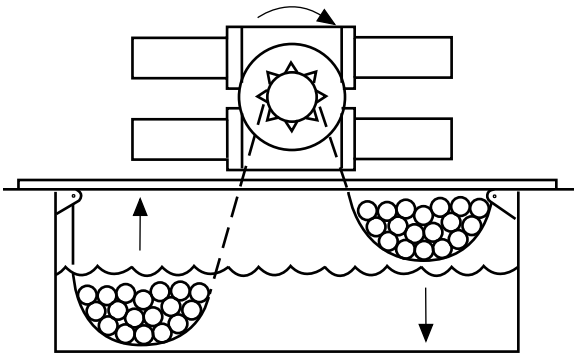

TUBE PICKLING DRIVE CONVEYOR

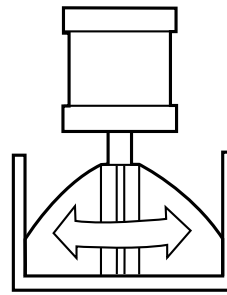

MIXING

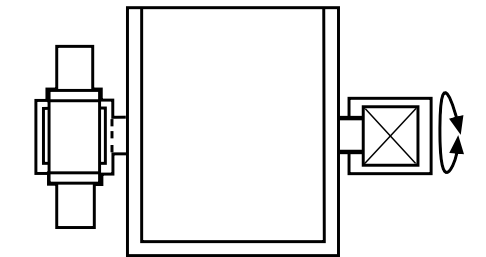

WELDING FRAME ROLLOVER

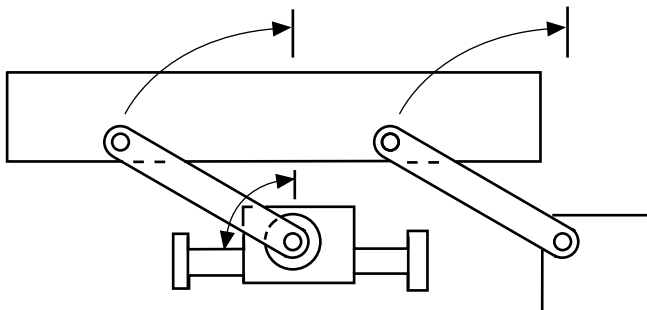

**TRANSFER
(LIFTING/FEEDING)**

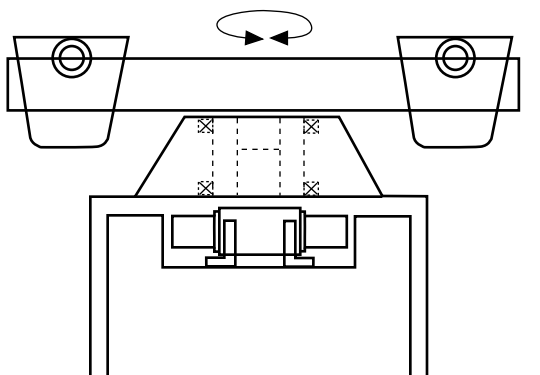

LADLE TURRET

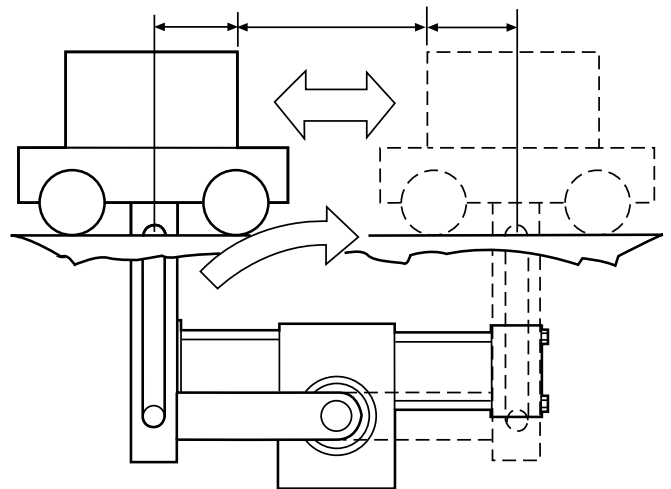

HARMONIC DRIVE

A rack and pinion rotary actuator consists of a housing with bearings, a rack and pinion gear rotary group and hydraulic cylinder parts. The cylinder pistons drive the rack gear across the pinion gear to generate torque at some rotational velocity. Gear tooth life is well understood and with the help of the AGMA 2001-B88 calculation model, we can make gear train life estimates. The following tables suggest a relationship between a desired total torque value and a desired durability cycle life.

Durability Cycle Life

A gear tooth can break either when overloaded or by load induced metal fatigue. The tooth overload failure mode is obvious. Parker and our competitors have historically used the "bending stress" criteria to establish torque ratings. Tooth bending capability remains a useful criteria. Parker proposes to broaden the selection criteria by publishing torque versus durability life guidelines and suggestions.

Parker Automation Actuator Division has generated the following tables as an actuator selection aid. We suggest actuator selection begin with the consideration of both torque and desired durability life. Use these tables to discover possible candidate LTR, HTR and Mill type actuators for consideration.

How to Use

These suggestions are made not respective of the available operational pressure. Select the desired total torque requirements on the left hand column. Then select the desired durability cycle life column. In that square, find an actuator suggestion that should meet both the gear train durability and cycle life criteria. An actuator with greater capabilities than the one suggested should satisfy the same criteria. For example, if the block suggests an LTR151 for the given torque and durability life, then an LTR152 is also suitable as would be an HTR1.8 or any actuator larger than the LTR151.

Caution: These charts are intended as a guide only. Refer to actual product data in the catalog before specifying an actuator. Factors such as bearing loads and shock loads may influence actuator selection. It is not feasible for any catalog to note, describe and anticipate all product limitations. It is incumbent upon the OEM or user to qualify any particular product for each and every application.

NOTE: Consult factory for gear train life information if:

- LTR system pressure exceeds 750 psig
- HTR system pressure exceeds 1750 psig
- M system pressure exceeds 2250 psig

Completely fill out the "Application Fax" and submit the form prior to contact with the factory.

Torque vs Durability Cycle Life*

Torques from 200 to 1100 lb-in

Torque Level		10 thousand Cycles Nominal Life	100 thousand Cycles Nominal Life	1 million Cycles Nominal Life	10 million Cycles Nominal Life
lb-in	Nm				
1100	124	LTR151	HTR1.8	HTR3.7	LTR152
1000	113	LTR151	HTR1.8	HTR1.8	LTR152
900	102	LTR151 or HTR.9	LTR151	HTR1.8	HTR3.7
800	90	HTR.9	LTR151	HTR1.8	HTR1.8
700	79	LTR102 or HTR.9	LTR151	LTR151	HTR1.8
600	68	LTR102 or HTR.9	LTR102 or HTR.9	LTR151	LTR151
500	57	LTR102 or HTR.9	LTR102 or HTR.9	LTR102 or HTR.9	LTR151
400	45	LTR101	LTR102 or HTR.9	LTR102 or HTR.9	LTR102 or HTR.9
300	34	LTR101	LTR101	LTR102 or HTR.9	LTR102 or HTR.9
200	23	LTR101	LTR101	LTR101	LTR101

*Durability life estimates based on AGMA 2001-B88 gear life model for pitting resistance.

Torque vs Durability Cycle Life*

Torques from 2000 to 10000 lb-in

Torque Level		10 thousand Cycles Nominal Life	100 thousand Cycles Nominal Life	1 million Cycles Nominal Life	10 million Cycles Nominal Life
lb-in	Nm				
10000	1130	HTR10 or LTR321	LTR322	HTR30/45	HTR30/45
9000	1017	HTR10	HTR15/22	HTR30/45	HTR30/45
8000	904	HTR10 or LTR252	HTR15/22	LTR322	HTR30/45
7000	791	HTR7.5	HTR10	HTR15/22	HTR30/45
6000	678	LTR321/252	HTR10	HTR15/22	HTR30/45
5000	565	HTR5 or LTR202/252	LTR202/321	HTR10	HTR15/22
4000	452	LTR202/251	LTR202/321	LTR202/321	HTR10
3000	339	HTR3.7 or LTR251	HTR5	LTR202/321	LTR321
2000	226	HTR1.8 or LTR152	HTR1.8/3.7 or LTR152	LTR101/251/152 or HTR5	LTR201/251/152

Torque vs Durability Cycle Life*

Torques from 15000 to 100000 lb-in

Torque Level		10 thousand Cycles Nominal Life	100 thousand Cycles Nominal Life	1 million Cycles Nominal Life	10 million Cycles Nominal Life
lb-in	Nm				
100000	11300	150M or HTR150	150M	150M	150M or HTR300
90000	10170	150M or HTR150	150M	150M	150M or HTR300
80000	9040	150M or HTR150	150M	150M	150M or HTR300
70000	7910	75M or HTR75	75M	150M	150M or HTR300
60000	6780	75M or HTR75	75M or HTR150	75M or HTR150	150M or HTR300
50000	5650	75M or HTR75	75M or HTR150	75M or HTR150	75M or HTR150
40000	4520	75M or HTR75	75M or HTR150	75M or HTR150	75M or HTR150
30000	3390	HTR30	HTR75	75M or HTR150	75M or HTR150
20000	2260	HTR30/45 or LTR322	HTR30/45	HTR75	HTR75
15000	1695	HTR15/22 or LTR322	HTR30/45	HTR30/45	HTR30/45

Torque vs Durability Cycle Life*

Torques from 100000 to 600000 lb-in

Torque Level		10 thousand Cycles Nominal Life	100 thousand Cycles Nominal Life	1 million Cycles Nominal Life	10 million Cycles Nominal Life
lb-in	Nm				
600000	67764	600M or HTR600			
500000	56470	600M or HTR600	600M		
400000	45176	600M or HTR600	600M	600M	
300000	33882	300M or HTR300	600M or HTR600	600M	600M
200000	22588	300M or HTR300	300M	600M or HTR600	600M or HTR600
100000	11300	150M or HTR150	150M or HTR300	150M or HTR300	150M or HTR300

*Durability life estimates based on AGMA 2001-B88 gear life model for pitting resistance.

LTR Series **Section A**

The LTR Series will provide superior performance in low pressure hydraulic applications found in packaging, material handling, machine tool and automated assembly industries.

Sealed ball bearings and floating pistons ensure low breakaway pressure and smooth operation. PolyPak piston seals and wearbands eliminate leakage and cylinder scoring. Alloy steel racks and pinions provide the strength and resilience for minimum downtime. A broad offering of options provides unmatched flexibility in design and application. These include cushions, stroke adjusters, flow controls, and position sensors, as well as application matched shaft, mounting, porting and seal variations. Three position and antibacklash units are also available.

SPECIFICATIONS

- **Nominal Pressure:** 1000 psi
- **Standard Rotations:** 90°, 180°, 270°, 360°
- **Output Torque @ 1000 psi:** 395 to 22,500 lb-in
- **Maximum Breakaway Pressure:** 30 psi



HTR Series **Section B**

When durability, performance, and reliability are required in the most demanding industrial applications, specify the HTR Series actuator. This series is designed for medium duty service found in machine tool, transfer line, material handling and other critical applications.

Through hardened alloy steel pinion and racks, supported by large capacity tapered roller bearings in a ductile iron housing, ensure long life, even with externally applied radial and thrust loads. The heavy duty Wear-Pak pistons are equipped with self-energizing deep PolyPak piston seals and a rugged wear band for long life operation. Standard NFPA cylinder construction allows for a wide variety of rotation options, complementing the broad offering of shaft and mounting styles.

SPECIFICATIONS

- **Maximum Operating Pressure:** Up to 3000 psi non-shock
- **Standard Rotations:** 90°, 180°, 360°
- **Rotational Tolerance:** -0° + 2°
- **Output Torque @ 3000 psi:** 900 to 600,000 lb-in
- **Maximum Breakaway Pressure:** 75 psi



M Series **Section C**

Designed to meet steel mill specifications, these non tie rod rotary actuators incorporate a range of exclusive features designed to provide durability and dependability in the most arduous operating environment.

Wear band pistons on both ends and bronze bearings under the center of the alloy steel rack provide critical support and virtually eliminate scoring or galling of the cylinder tubes. Large diameter tapered roller bearings support the pinion, allowing the unit to absorb high external loads. PolyPak seals provide long life operation and, for ease of maintenance, can be changed without removing the actuator from the installation.

SPECIFICATIONS

- **Maximum Operating Pressure:** 3,000 psi
- **Proof Pressure:** 6,000 psi
- **Standard Rotations:** 90°, 180°, 270°, 360°
- **Rotational Tolerance:** -0" + 2"
- **Output Torque @ 3,000 psi:** 75,000 to 50,000,000 lb-in
- **Average Angular Backlash:** 10 minutes
- **Maximum Breakaway Pressure:** 100 psi
- **Housing:** Heavy duty ductile iron (units up to 1,000M)
Steel weldments (units larger than 1,000M)

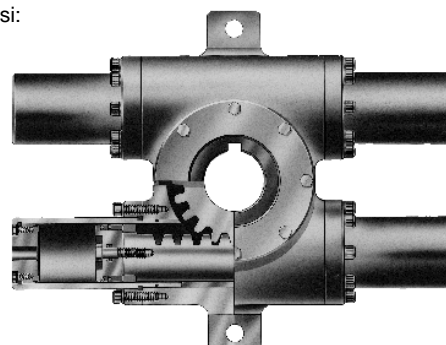

Rack & Pinion Hydraulic Rotary Actuators

LTR Series – Light Duty, 1000 psi – Section A

Introduction	1 - 3
Dimensions	4
Options	5 - 16
Engineering Data	17 - 19
Ordering Information	20 - 21

HTR Series – Medium Duty, 3000 psi – Section B

Introduction	1 - 4
Dimensions	5 - 6
Options	7 - 12
Engineering Data	13 - 14
Special Options	15 - 19
Ordering Information	20 - 21

M Series – Mill Duty, 3000 psi – Section C

Introduction	1 - 4
Dimensions	5 - 7
Options	8 - 12
Engineering Data	13 - 14
Ordering Information	15

Engineering and Application Information – Section D

