

Disassembly and Reassembly Instructions for Cylinders Containing Springs Under Compression

⚠ WARNING: Improper disassembly or reassembly of cylinders containing springs may cause serious personal injury. It is therefore important that the procedure listed below is strictly followed. Because of the generally larger spring loads it is suggested that cylinder 10 inch bore and larger be sent back to the factory for repairs.

Procedure:

- 1) If the cylinder already contains tie rods with extended thread skip to step 7.
- 2) If, on the spring end of the cylinder, tie rods are threaded into the head or cap, disassemble and reassemble from the opposite end.
- 3) Remove two tie rods from opposite corners as shown in Figure 1.
- 4) If the cylinder does not contain tie rods with extended thread obtain two (2) of them for bore sizes less than 10 inch or four (4) if larger or equal to 10 inch bore by calling the Cylinder Division at (847) 298 2400 and providing the cylinder serial number.
- 5) Install two tie rods with the extended thread per Figure 2. Normally the extended threaded end should be at the spring end of the cylinder. Tighten tie rod nuts hand tight.
- 6) Remove remaining two tie rods per Figure 3.
- 7) For cylinders bore sizes 10 inch and larger install the other two tie rods with extended thread similarly to step 5.
- 8) Loosen tie rod nuts on the extended threaded side while holding the tie rod with vise grips or similar making sure the tie rod is not unthreading from the opposite end. Loosen the nuts alternately corner to corner until the spring is completely decompressed as shown in Figure 4. The cylinder may now be completely disassembled and repaired.
- 9) Repair cylinder following the instructions in the service bulletin provided with the repair kit.
- 10) Reassemble the cylinder by reversing the disassembly procedure listed above.

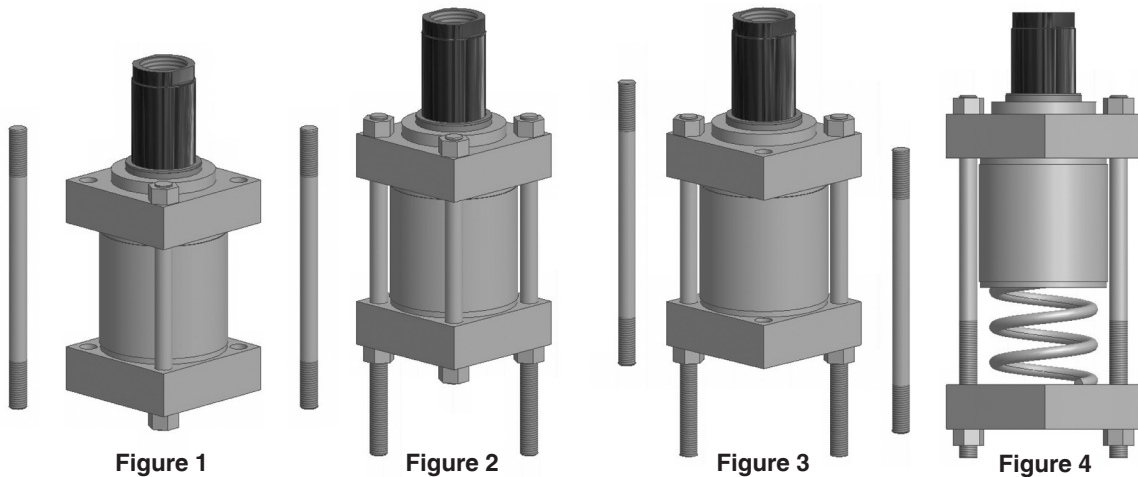

Spring on Cap End

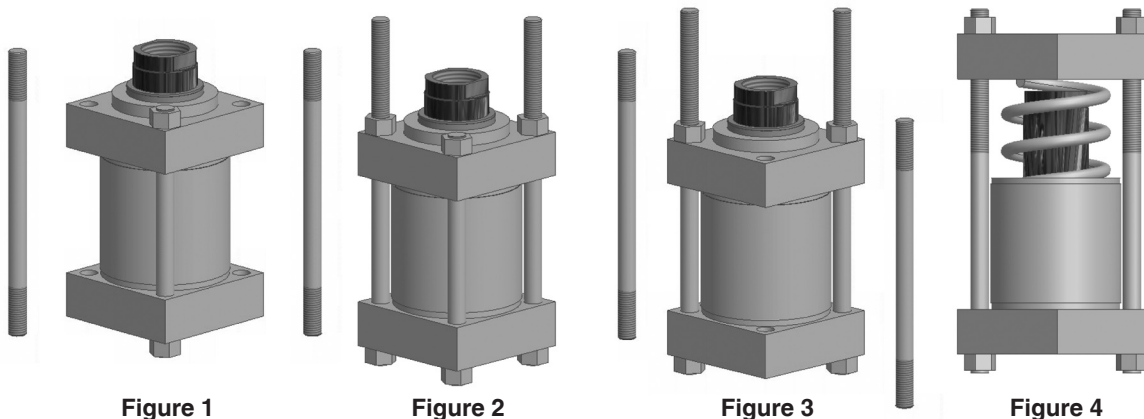

Spring on Rod End