

Characteristics / Ordering Code

Pilot operated check valves from the Parker Manapak series CPOM are in sandwich design for easy configuration of stack systems. Depending on the function required, one or two pilot operated check valves are arranged in the ports A and/or B. The free flow direction is always from the valve side to the manifold side.

Function

The check valves open when flowing to the consumer side, where the opposing check valve is hydraulically-mechanically pilot operated simultaneously by a control spool, and thus the return flow is enabled from other consumer sides.

Features

- The valve bodies of the Parker Manapak valve series CPOM are made of steel.
- The valve poppet is precisely guided into the steel sleeve and ensures a good seal on the seat.
- When the valve poppet is open, the large cross-section allows high flow rates at low differential pressure.
- Different control ratios can be chosen with the NG06 and NG10 valves.
- Pre-opening for CPOM*HT to achieve smooth opening.



CPOM3

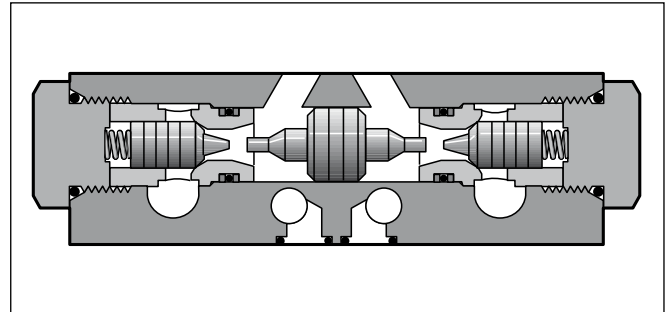
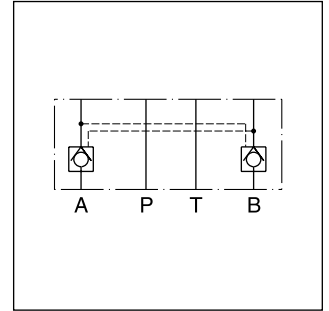

Ordering code

Without pre-opening

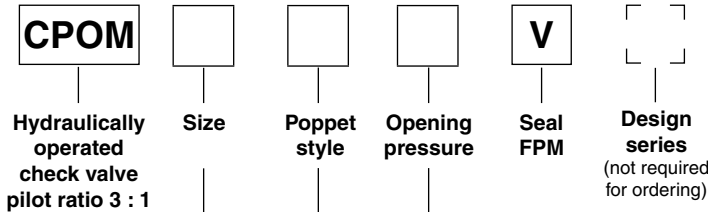

Code	Size
2	NG06
3	NG10
6	NG25

Code	Pressure	Size
omit	1.0 bar	NG06/10/25
25	2.5 bar	NG06
50	5.0 bar	NG06
70	7.0 bar	NG06

Code	Connection
AA	only A
BB	only B
DD	A and B

With pre-opening

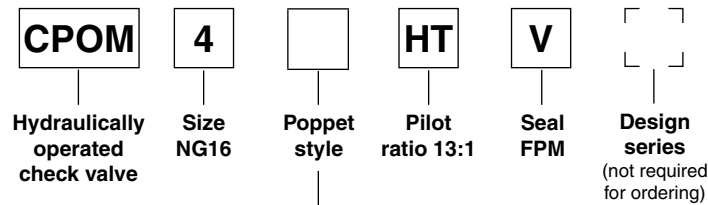

Code	Connection
AA	only A
BB	only B
DD	A and B

Bold letters = Short-term availability

CPOM UK.INDD CM 30.03.15



Technical Data / Schematics

Technical data

General					
Series		CPOM2	CPOM3	CPOM4	CPOM6
Nominal size		NG06	NG10	NG16	NG25
Mounting interface		ISO 4401			
Ambient temperature	[°C]	-20...+60			
MTTF _D value	[years]	150			
Weight	[kg]	1.8	4.0	7.65	9.5
Hydraulic					
Max. operating pressure	[bar]	350	350	350	210
Opening pressure	[bar]	1.0	0.8	2.0	0.4
Opening ratio		1 : 3	1 : 3	1 : 13	1 : 3
Fluid		Hydraulic oil according to DIN 51524			
Fluid temperature	[°C]	-20...+70			
Viscosity, permitted	[cSt] / [mm ² /s]	20...400			
Viscosity, recommended	[cSt] / [mm ² /s]	30...80			
Filtration		ISO 4406 (1999); 18/16/13			

Schematics

CPOM2 / CPOM3

CPOM4 / CPOM6

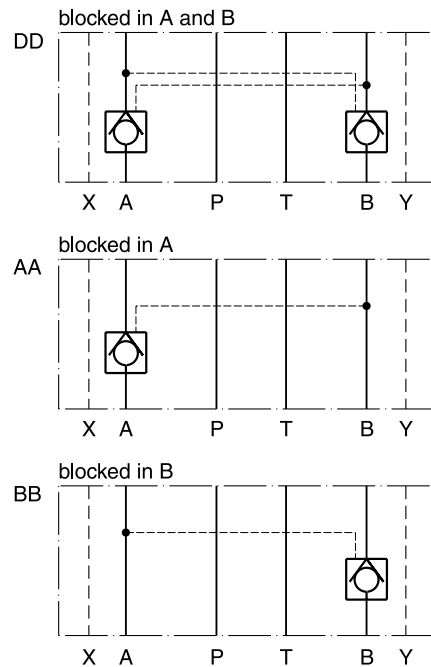
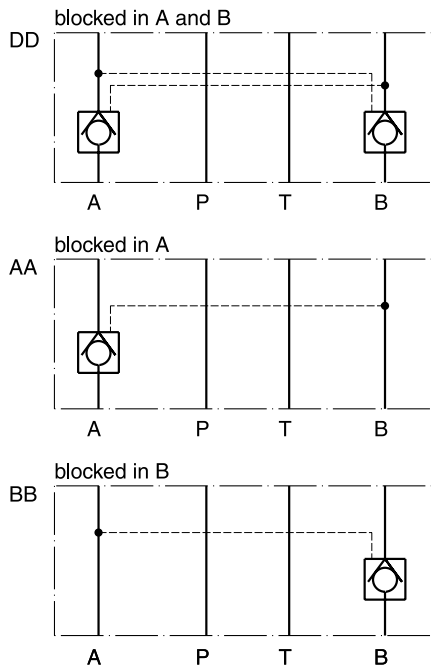

$\Delta p/Q$ performance curves

CPOM2

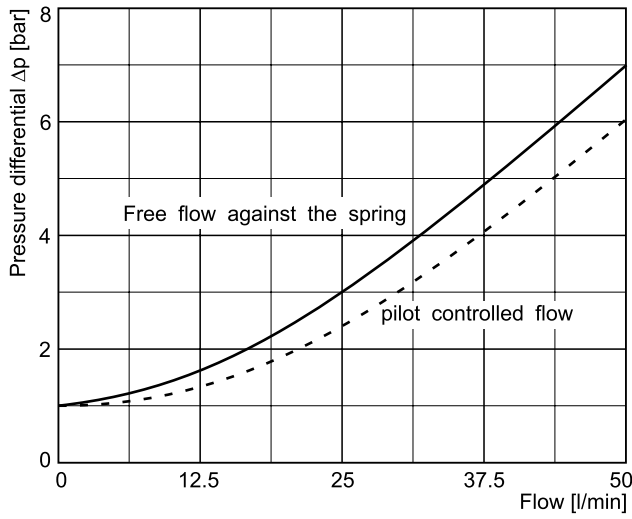

CPOM3

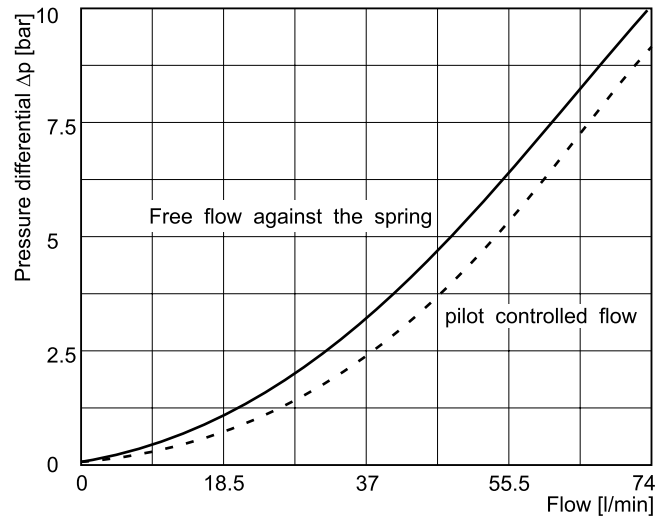

CPOM4 (type HT)

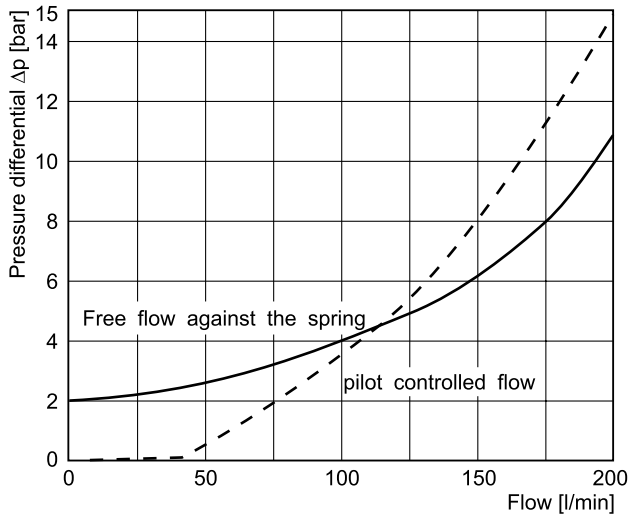

CPOM6

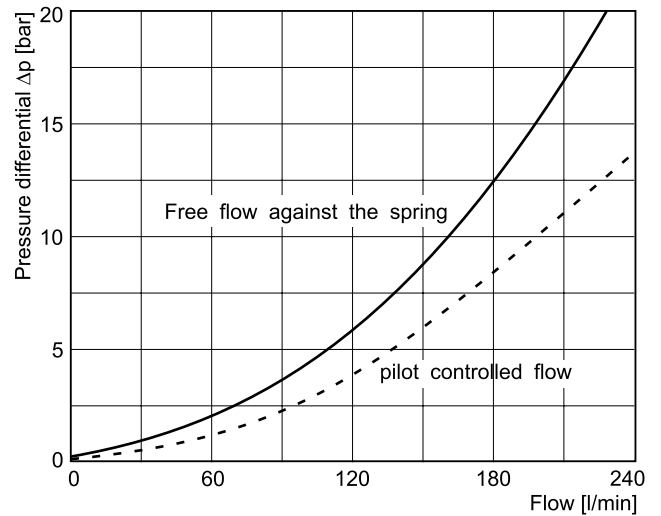

All characteristic curves measured with HLP46 at 50 °C.

7

Dimensions

CPOM2

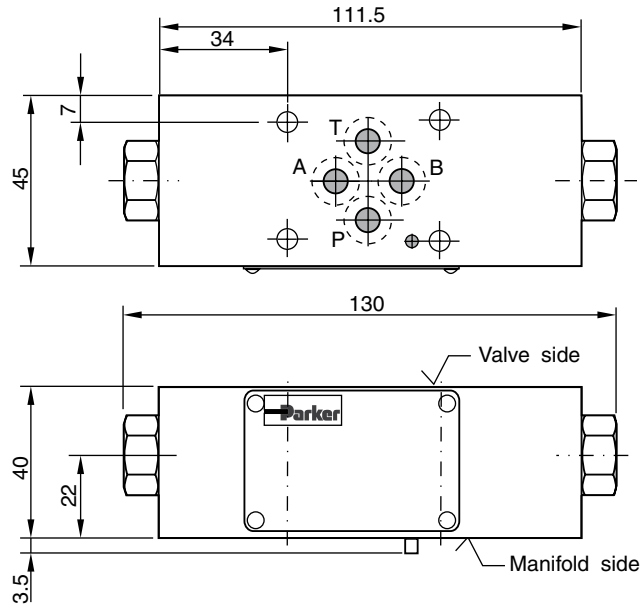

Seal kit CPOM2	
Seal	Order code
V	SK-CPOM2-V-11

7

CPOM3

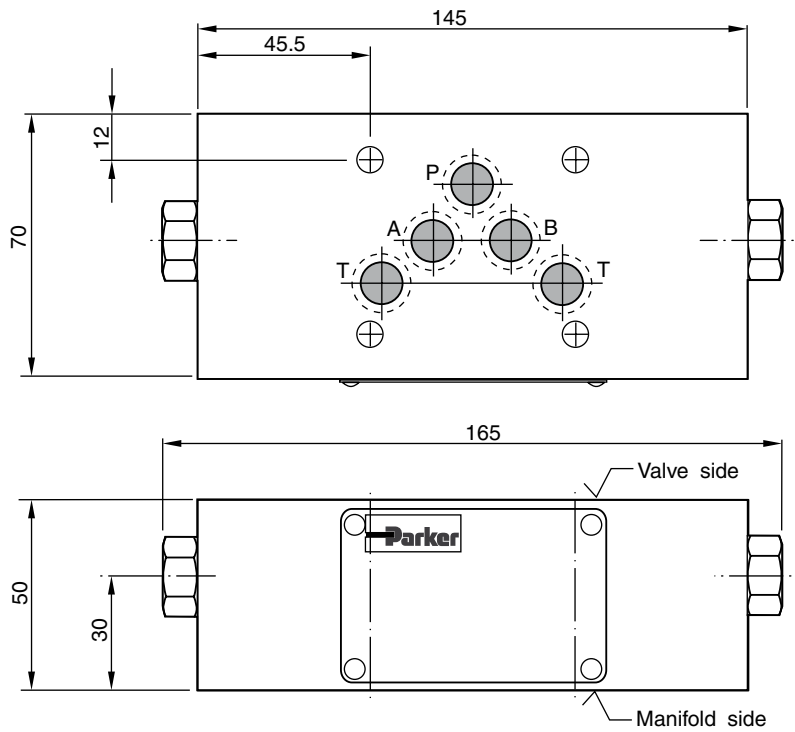

Seal kit CPOM3	
Seal	Order code
V	SK-CPOM3-V-11

Note:

The O-ring plate for sealing the connecting surface of the manifold side is included. The O-ring plate and the positioning pin are always mounted on the manifold side.

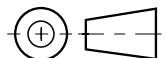

Dimensions

**Pilot Operated Check Valve
Series CPOM**

CPOM4

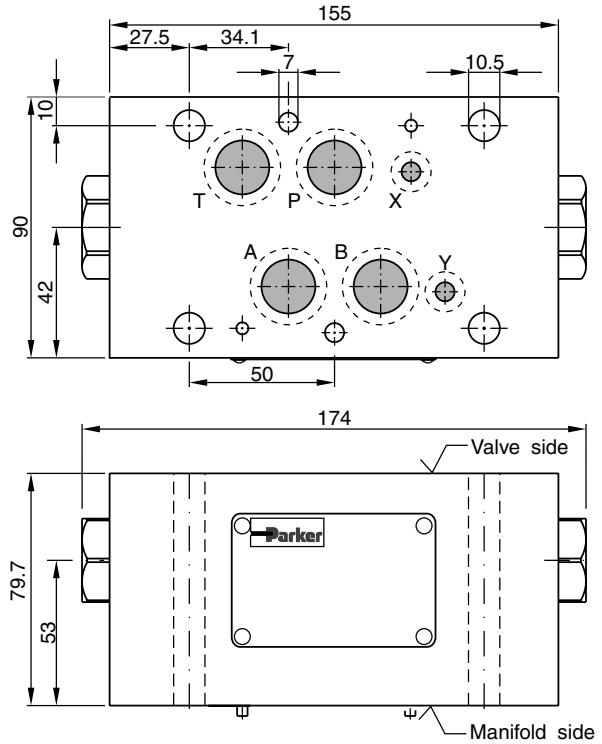

Seal kit CPOM4	
Seal	Order code
V	SK-CPOM4HTV

CPOM6

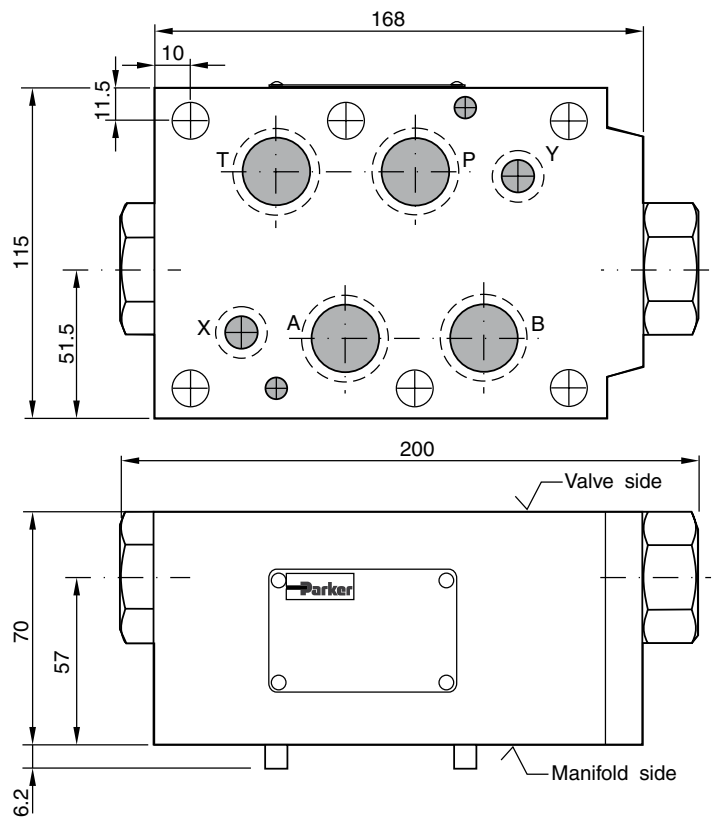

Seal kit CPOM6	
Seal	Order code
V	SK-CPOM6-V-20

Note:

The O-ring plate for sealing the connecting surface of the manifold side is included. The O-ring plate and the positioning pin are always mounted on the manifold side.

