

## HSL Filter Housings

- sanitary liquid

- Single element sanitary liquid housing
- Designed specifically for the food & beverage and pharmaceutical industries
- Sanitary tri-clamp body closure as standard
- STANDARD product
  - Sanitary surface finish
  - Tri-clamp connections
- PLUS product
  - Available in 3 different vessel classes: Standard (CE), Atex and High Pressure
  - Sanitary or sanitary electropolished surface finish options
  - Wide range of vent and drain connections
  - Choice of gasket and seal materials



### Specification

#### STANDARD Range Materials of Construction

- Housing: 316L Stainless Steel
- Seals: Silicone FDA
- Clamps: 304 Stainless Steel

#### Surface Finish

- Internal: Polished 0.4 µm Ra (16 µIn Ra)
  - External: Polished 0.25 µm Ra (10 µIn Ra)
- All finishes pickled & passivated.*

#### PLUS Range Materials of Construction

- Housing: 316L Stainless Steel
- Seals: EPDM FDA  
PTFE FDA  
Silicone FDA  
Viton FDA
- Clamps: 304 Stainless Steel

#### Surface Finish

- Sanitary Finish
  - Internal: Polished 0.4 µm Ra (16 µIn Ra)
  - External: Polished 0.25 µm Ra (10 µIn Ra)
- Sanitary Electropolished Finish
  - Internal: Polished 0.4 µm Ra (16 µIn Ra) and Electropolished
  - External: Polished 0.25 µm Ra (10 µIn Ra)

#### Welding

All assembly welds are full penetration. All welds are crevice and undercut free.

*Weld finish & detail drawings available upon request.*

#### Certification

Supplied as standard with vessel inspection certificate.

#### Material Test Certification

EN10204 3.1 supplied upon request.

#### Design Code

Housings designed in accordance with the European Council Pressure Equipment Directive (PED) 97/23/EC and the UK statutory Pressure Equipment Regulations (PER) 1999 N° 2001.

PED / PER conformity assessments based on Fluid Group 2 Gas (harmless) including steam. Only housings over PS.V 50 bar / litres bear the CE mark.

#### Design Basis

ASME VIII Division 1.

## Standard Range

Working Condition PED 97/23/EC			Maximum Pressure				
Fluid Group	State	Temperature	01A	01B	011	012	013
Non Dangerous	Liquid / Gas	150 °C (302 °F)	10.00 barg (145.03 psig)	10.00 barg (145.03 psig)	10.00 barg (145.03 psig)	10.00 barg (145.03 psig)	10.00 barg (145.03 psig)
Dangerous	Liquid / Gas	150 °C (302 °F)	10.00 barg (145.03 psig)	10.00 barg (145.03 psig)	5.00 barg (72.51 psig)	5.00 barg (72.51 psig)	5.00 barg (72.51 psig)
PED Conformity Assessment Category			SEP	SEP	SEP	SEP	CAT I
Volume (litres)			0.75	0.5	2.9	4.8	6.7

## Plus Range

CE Working Condition PED 97/23/EC			Maximum Pressure						
Fluid Group	State	Temperature	01A	01B	01K	011	012	013	014
Non Dangerous	Gas / Vapour	150 °C (302 °F)	10.00 barg (145.03 psig)	10.00 barg (145.03 psig)	10.00 barg (145.03 psig)	10.00 barg (145.03 psig)	10.00 barg (145.03 psig)	10.00 barg (145.03 psig)	10.00 barg (145.03 psig)
Dangerous	Gas / Vapour	150 °C (302 °F)	10.00 barg (145.03 psig)	10.00 barg (145.03 psig)	5.00 barg (72.51 psig)	5.00 barg (72.51 psig)	5.00 barg (72.51 psig)	5.00 barg (72.51 psig)	5.00 barg (72.51 psig)
Non Dangerous	Liquid	150 °C (302 °F)	10.00 barg (145.03 psig)	10.00 barg (145.03 psig)	10.00 barg (145.03 psig)	10.00 barg (145.03 psig)	10.00 barg (145.03 psig)	10.00 barg (145.03 psig)	10.00 barg (145.03 psig)
Dangerous	Liquid	150 °C (302 °F)	10.00 barg (145.03 psig)	10.00 barg (145.03 psig)	5.00 barg (72.51 psig)	5.00 barg (72.51 psig)	5.00 barg (72.51 psig)	5.00 barg (72.51 psig)	5.00 barg (72.51 psig)
PED Conformity Assessment Category			SEP	SEP	SEP	SEP	SEP	CAT I	CAT I
Volume (litres)			0.75	0.5	1.7	2.9	4.8	6.7	8.6

ATEX Working Condition PED 97/23/EC			Maximum Pressure						
Fluid Group	State	Temperature	01A	01B	01K	011	012	013	014
Non Dangerous	Gas / Vapour	135 °C (275 °F)	10.00 barg (145.03 psig)	10.00 barg (145.03 psig)	10.00 barg (145.03 psig)	10.00 barg (145.03 psig)	10.00 barg (145.03 psig)	10.00 barg (145.03 psig)	10.00 barg (145.03 psig)
Dangerous	Gas / Vapour	135 °C (275 °F)	10.00 barg (145.03 psig)	10.00 barg (145.03 psig)	5.00 barg (72.51 psig)	5.00 barg (72.51 psig)	5.00 barg (72.51 psig)	5.00 barg (72.51 psig)	5.00 barg (72.51 psig)
Non Dangerous	Liquid	135 °C (275 °F)	10.00 barg (145.03 psig)	10.00 barg (145.03 psig)	10.00 barg (145.03 psig)	10.00 barg (145.03 psig)	10.00 barg (145.03 psig)	10.00 barg (145.03 psig)	10.00 barg (145.03 psig)
Dangerous	Liquid	135 °C (275 °F)	10.00 barg (145.03 psig)	10.00 barg (145.03 psig)	5.00 barg (72.51 psig)	5.00 barg (72.51 psig)	5.00 barg (72.51 psig)	5.00 barg (72.51 psig)	5.00 barg (72.51 psig)
PED Conformity Assessment Category			SEP	SEP	SEP	SEP	SEP	CAT I	CAT I
Volume (litres)			0.75	0.5	1.7	2.9	4.8	6.7	8.6

High Pressure Working Condition PED 97/23/EC			Maximum Pressure						
Fluid Group	State	Temperature	01A	01B	01K	011	012	013	014
Non Dangerous	Gas / Vapour / Liquid	205 °C (401 °F)	16.00 barg (232.06 psig)	16.00 barg (232.06 psig)	16.00 barg (232.06 psig)	16.00 barg (232.06 psig)	16.00 barg (232.06 psig)	16.00 barg (232.06 psig)	16.00 barg (232.06 psig)
PED Conformity Assessment Category			SEP	SEP	SEP	SEP	CAT I	CAT I	CAT I
Volume (litres)			0.75	0.5	1.7	2.9	4.8	6.7	8.6

Note: All housings are fully vacuum rated.

## Physical Characteristics

Bowl Height	Dimensions (mm)			Typical Weight
	'A'	'B'	'C'	
A Size 125 mm (5")	117 mm (4.6")	191 mm (7.5")	130 mm (5.1")	2.0 Kg (4.4lbs)
B Size 65 mm (2½")	117 mm (4.6")	136 mm (5.4")	70 mm (2.8")	1.8 Kg (3.9lbs)
250 mm (10")	156 mm (6.1")	417 mm (16.4")	313 mm (12.3")	3.8 Kg (8.3 lbs)
500 mm (20")	156 mm (6.1")	667 mm (26.3")	561 mm (22.1")	4.8 Kg (10.5 lbs)
750 mm (30")	156 mm (6.1")	912 mm (35.9")	809 mm (31.8")	5.7 Kg (12.5 lbs)
1000 mm (40")	156 mm (6.1")	1160 mm (45.7")	1057 mm (41.6")	6.7 Kg (14.7 lbs)

Dimensions shown are based on the STANDARD range. For accurate dimensions, please contact Parker domnick hunter.

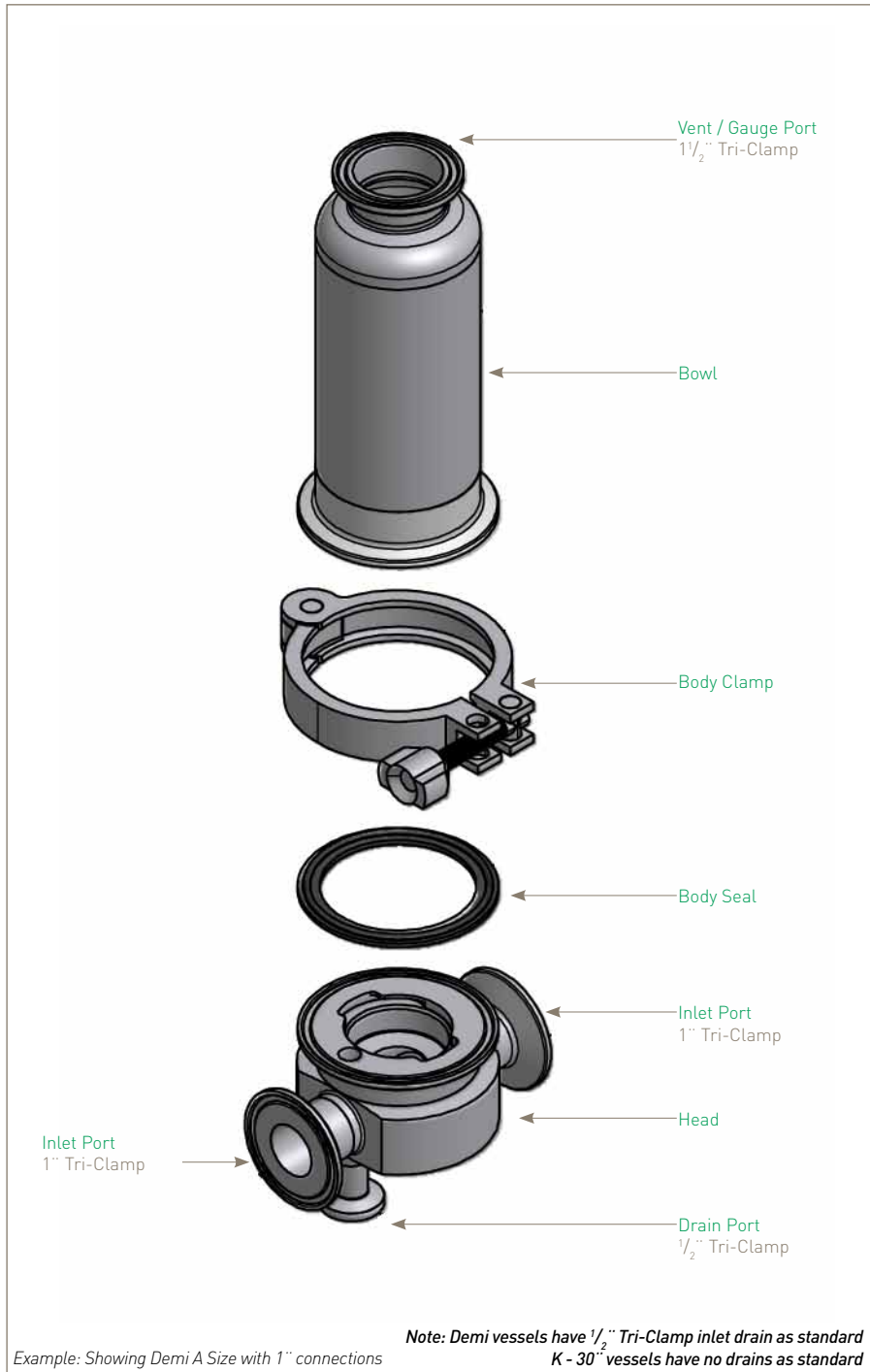
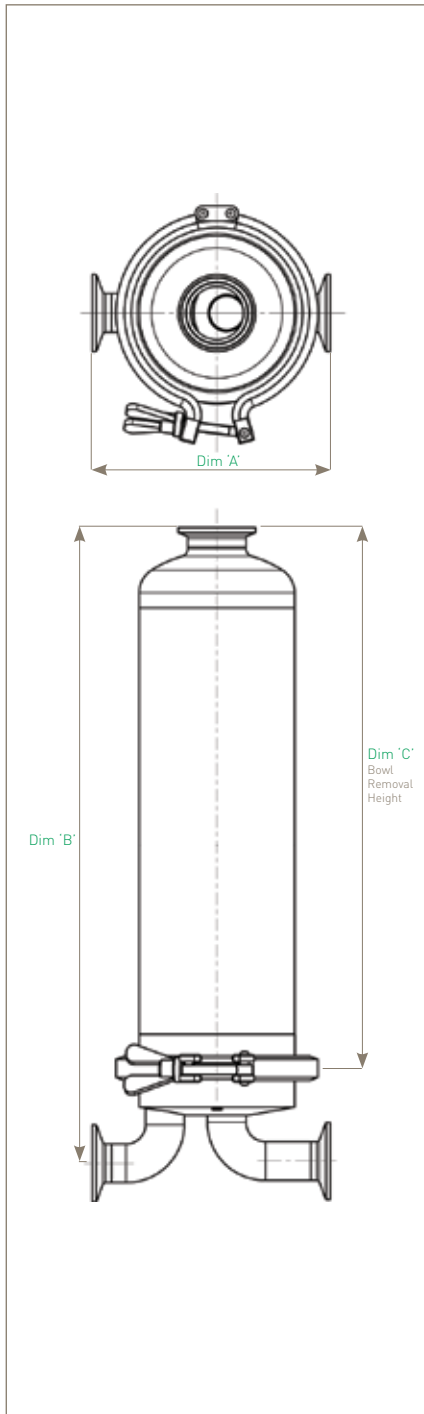

The PLUS product range is available with many options of connections, vents, drains, surface finish, seals classification, etc. Please see product coding.

## STANDARD Range - 10" to 30"

HSL  01   -  -

Code   Vessel Class	Code   Length (Nominal)	Code   Connection Size	Code   Standard	Code   Cartridge	Code   Seal
CE Standard	1 10" (250 mm) 2 20" (500 mm) 3 30" (750 mm)	B 1" (25.4 mm)	T Tri-Clamp	C 226	S Silicone

Note: No drain(s) as standard.

## STANDARD Range - Demi A & B

HSL  01   -  -

Code   Vessel Class	Code   Length (Nominal)	Code   Connection Size	Code   Standard	Code   Cartridge	Code   Seal
CE Standard	A 5" (125 mm) B 2 1/2" (65 mm)	B 1"	T Tri-Clamp	T 216	S Silicone

Note: 1/2" Tri-Clamp inlet drain as standard.

## PLUS Range - K to 40"

HSL  01    -   -  -

Code   Vessel Class	Code   Length (Nominal)	Code   Connection Size	Code   Standard	Code   Cartridge	Code   Seal	Code   Vent	Code   Drain								
CE Standard AT ATEX HP* High Pressure	K 5" (125 mm) 1 10" (250 mm) 2 20" (500 mm) 3 30" (750 mm) 4 40" (1000 mm)	B 1" (25.4 mm)	D DIN11851(M) F <sup>(1)(2)</sup> ANSI RF 150 H <sup>(2)</sup> ANSI RF 300 L BS4504 DIN2633 R RJT(M) S SMS Union (M) T Tri-Clamp W ISO / BS Pipe	C 226	E EPDM P* PTFE S Silicone V Viton	A 1/2" TCF & 2 x Rectus 21 E 1/2" TCF & 2 x Staubli RBE03 H 1/2" TCF & Hosebarb I 1/2" TCF & Staubli RBE03 M 1 1/2" TCF & 1/2" TCF R 1/2" TCF & Rectus 21 S Staubli RBE03 Vertical T 1/2" TCF Only	H Hosebarb Inlet Only R Rectus 21 Inlet Only S Staubli RBE03 Inlet Only X No Drain Y 1" TCF Inlet Only Z 1" TCF Inlet & Outlet								
* Supplied complete with a double bolted clamp		<sup>(1)</sup> Not suited for High Pressure Vessels. HP Vessels to use ANSI RF 300. <sup>(2)</sup> Flanged vessels based on 1" O.D. pipe but use 1/4" or NW20 flanges.		<b>Code   Surface Finish</b> <table border="1"> <thead> <tr> <th></th> <th>Internal</th> <th>External</th> </tr> </thead> <tbody> <tr> <td>B Sanitary</td> <td>0.4 µm</td> <td>0.25 µm</td> </tr> <tr> <td>P Sanitary Electropolished</td> <td>0.4 µm EP</td> <td>0.25 µm</td> </tr> </tbody> </table>			Internal	External	B Sanitary	0.4 µm	0.25 µm	P Sanitary Electropolished	0.4 µm EP	0.25 µm	<b>Code   Tagged</b> T Yes X No
	Internal	External													
B Sanitary	0.4 µm	0.25 µm													
P Sanitary Electropolished	0.4 µm EP	0.25 µm													

For Tagged Options customer identification numbers required at time of ordering

## PLUS Range - Demi A & B

HSL  01   -  -

Code   Vessel Class	Code   Length (Nominal)	Code   Connection Size	Code   Standard	Code   Cartridge	Code   Seal	Code   Vent	Code   Drain								
CE Standard AT ATEX HP High Pressure	A 5" (125 mm) B 2 1/2" (65 mm)	B 1"	D DIN11851 F <sup>(1)(2)</sup> ANSI RF 150 H <sup>(2)</sup> ANSI RF 300 L BS4504 DIN2633 R RJT S SMS Union (M) T Tri-Clamp W ISO / BS Pipe	T 126	E EPDM P* PTFE S Silicone V Viton	A 1/2" TCF & 2 x Rectus 21 B 1/2" TCF & 2 x Staubli RBE03 H 1/2" TCF & Hosebarb I 1/2" TCF & Staubli RBE03 M 1 1/2" TCF & 1/2" TCF R 1/2" TCF & Rectus 21 S Staubli RBE03 T 1/2" TCF Only	H Hosebarb Inlet Only R Rectus 21 Inlet Only S Staubli RBE03 Inlet Only T 1/2" TCF Inlet Only X No Drain								
		<sup>(1)</sup> Not suited for High Pressure Vessels. HP Vessels to use ANSI RF 300. <sup>(2)</sup> Only available in 1/4".		<b>Code   Surface Finish</b> <table border="1"> <thead> <tr> <th></th> <th>Internal</th> <th>External</th> </tr> </thead> <tbody> <tr> <td>B Sanitary</td> <td>0.4 µm</td> <td>0.25 µm</td> </tr> <tr> <td>P Sanitary Electropolished</td> <td>0.4 µm EP</td> <td>0.25 µm</td> </tr> </tbody> </table>			Internal	External	B Sanitary	0.4 µm	0.25 µm	P Sanitary Electropolished	0.4 µm EP	0.25 µm	<b>Code   Tagged</b> T Yes X No
	Internal	External													
B Sanitary	0.4 µm	0.25 µm													
P Sanitary Electropolished	0.4 µm EP	0.25 µm													

For Tagged Options customer identification numbers required at time of ordering